

CSi5 Crane Scale 3 000 kg



Available models

LT	NT
3 000 kg / 1 kg	3 000 kg / 0,5 kg

Functions

- ▼ Simple weighing
- ▼ Counting*
- ▼ Checkweighing*
- ▼ Animal weighing

Metrological Characteristics

- ▼ Legal Metrology Class III / IV
- ▼ LT Range 3000 e
- ▼ NT Range 6000 e

Environment

- ▼ Operating temperature $-10^{\circ}\text{C} \leq T \leq +40^{\circ}\text{C}$
- ▼ Charging battery temperature $0^{\circ}\text{C} \leq T \leq +30^{\circ}\text{C}$
- ▼ Storage temperature $-20^{\circ}\text{C} \leq T \leq +60^{\circ}\text{C}$
- ▼ Moisture 85%
- ▼ Sealing IP66

Power Supply

- ▼ Network voltage (option)
 - Voltage 100 - 240 VAC
 - Frequency 50 - 60 Hz
 - Consumption 0,2 A
- ▼ Internal battery
 - Autonomy - Backlight off 40 h
 - Autonomy - Backlight on 15 h
 - Charge time - From 0 to 100% 7 h
 - Charge time - From 0 to 80% 4 h

Design

- ▼ 8 digit LCD display - Height 33 mm - Backlight.
- ▼ Upper cover in brushed stainless steel - Lower cover in painted steel red RAL 3020
- ▼ Weighing mechanism in zinc-plated steel IP 66
- ▼ Protection from shocks and overloads with two screws - Safety factor K = 4.
- ▼ Upper fastening: steel lifting ring
- ▼ Lower load fastening: approved hook with safety latch
- ▼ Package: cardboard box - 560 mm x 450 mm x 300 mm (L x W x H)

European Compliance

- ▼ European compliance
 - European Directive relative to Low Voltage Equipment
 - European Directive relative to Machines
 - European Directive relative to Electromagnetic Compatibility
 - European Directive relative to Non-Automatic Weighing Instruments (NAWI)
- ▼ Documentation
 - User manual CSi5 03-24-03-01 MU
 - User manual i5 Indicator 04-45-01-1 MU
 - Installation manual i5 Indicator 04-45-01-1 MI



Accessories Supplied

- ▼ 7" touch tablet for remote control with the *Weigh2control* application, *Bluetooth* link for the instrument and *Wi-Fi* link for data transfer with the computer network. Supplied with charger.
- ▼ Charger for removable battery

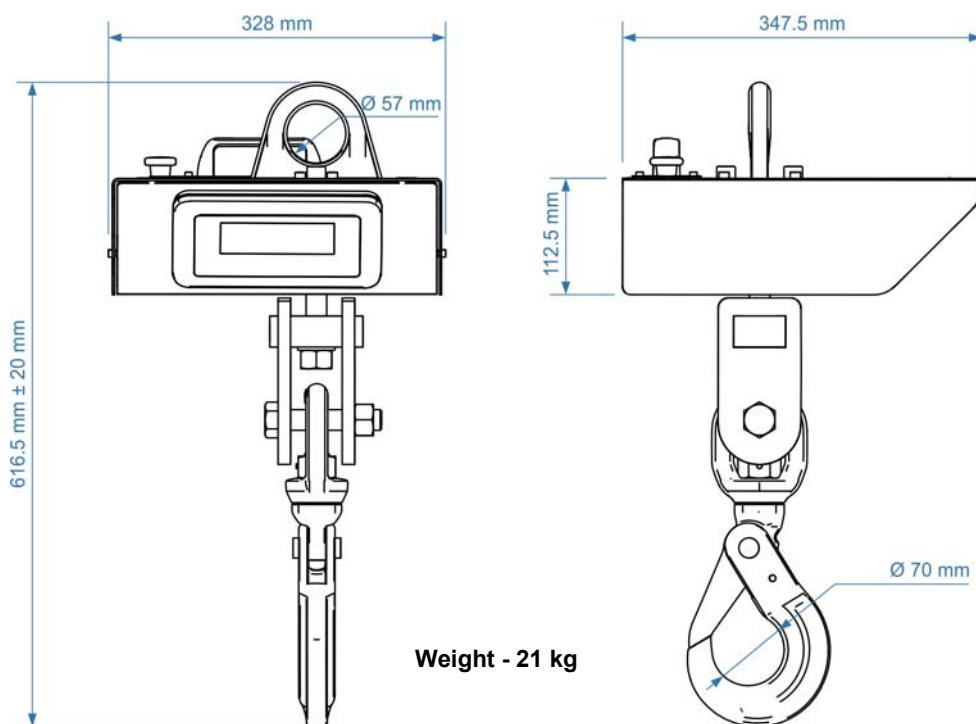
Dimensions



Options & Accessories

Functions	Accessories for Tablet	Additional Removable Battery	Painted steel bumper Red RAL 3020
<ul style="list-style-type: none"> • Application comptage • Application Contrôle +/- • Nombre de fiches illimité • Liaison Wifi 	<ul style="list-style-type: none"> • Protection • Power Bank 		

Your Specialist

Precia Molen reserves the right to alter the characteristics of the equipment described in this brochure at any time.

Headquarters & Factory PRECIA-MOLEN
 BP 106 - 07000 Privas - France
 Tel. 33 (0) 475 664 600
 Fax 33 (0) 475 664 330
 E-MAIL webmaster@preciamolen.com

RCS: 386 620 165 RCS Aubenas

**PRECIA
 MOLEN™**
 WORLDWIDE WEIGHING